

Profipress

Instructions for Use

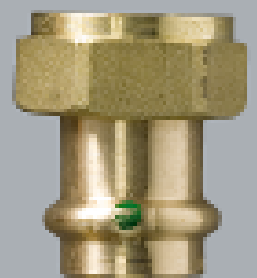
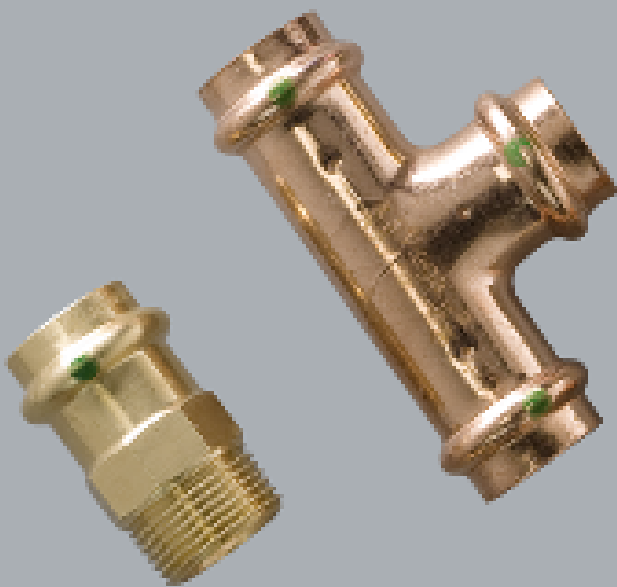

Year built:
from 05/1994
en_INT

viega

Table of contents

1	About these instructions for use	5
1.1	Target groups	5
1.2	Labelling of notes	5
1.3	About this translated version	6
2	Product information	7
2.1	Standards and regulations	7
2.2	Intended use	9
2.2.1	Areas of use	9
2.2.2	Media	10
2.3	Product description	10
2.3.1	Overview	10
2.3.2	Pipes	11
2.3.3	Press connectors	14
2.3.4	Sealing elements	15
2.3.5	Markings on components	16
2.3.6	Mixed installations	16
2.4	Information for use	17
2.4.1	Corrosion	17
3	Handling	18
3.1	Transport	18
3.2	Storage	18
3.3	Assembly information	18
3.3.1	Mounting instructions	18
3.3.2	Potential equalisation	19
3.3.3	Permitted exchange of sealing elements	19
3.3.4	Space requirements and intervals	20
3.3.5	Required tools	22
3.4	Assembly	23
3.4.1	Replacing the sealing element	23
3.4.2	Bending pipes	24
3.4.3	Shortening the pipes	24
3.4.4	Deburring the pipes	25
3.4.5	Pressing the connection	26
3.4.6	Leakage test	27
3.5	Maintenance	27

3.6 Disposal _____ 28

1 About these instructions for use

Trade mark rights exist for this document; for further information, go to viega.com/legal.

1.1 Target groups

The information in this manual is directed at heating and sanitary professionals and trained personnel.

Individuals without the abovementioned training or qualification are not permitted to mount, install and, if required, maintain this product. This restriction does not extend to possible operating instructions.

The installation of Viega products must take place in accordance with the general rules of engineering and the Viega instructions for use.

1.2 Labelling of notes

Warning and advisory texts are set aside from the remainder of the text and are labelled with the relevant pictographs.



DANGER!

This symbol warns of possible life-threatening injury.



WARNING!

This symbol warns of possible serious injury.



CAUTION!

This symbol warns of possible injury.



NOTICE!

This symbol warns of possible damage to property.



This symbol gives additional information and hints.

1.3 About this translated version

This instruction for use contains important information about the choice of product or system, assembly and commissioning as well as intended use and, if required, maintenance measures. The information about the products, their properties and application technology are based on the current standards in Europe (e. g. EN) and/or in Germany (e. g. DIN/DVGW).

Some passages in the text may refer to technical codes in Europe/Germany. These should serve as recommendations in the absence of corresponding national regulations. The relevant national laws, standards, regulations, directives and other technical provisions take priority over the German/European directives specified in this manual: The information herein is not binding for other countries and regions; as said above, they should be understood as a recommendation.

2 Product information

2.1 Standards and regulations

The following standards and regulations apply to Germany / Europe and are provided as a support feature.

Regulations from section: Fields of application

Scope / Notice	Regulations applicable in Germany
Use of copper pipes in sprinkler extinguisher systems	DIN EN 1057
Application in fire extinguishing systems	DIN 14462
Planning, execution, operation and maintenance of drinking water installations	DIN EN 1717
Planning, execution, operation and maintenance of drinking water installations	DIN 1988
Planning, execution, operation and maintenance of drinking water installations	VDI/DVGW 6023
Planning, execution, operation and maintenance of drinking water installations	Trinkwasserverordnung (TrinkwV)

Regulations from section: Media

Scope / Notice	Regulations applicable in Germany
Suitability for drinking water	Trinkwasserverordnung (TrinkwV)
Suitability for heating water for pump hot water heating systems	VDI-Richtlinie 2035, Sheet 1 and Sheet 2

Regulations from section: Pipes

Scope / Notice	Regulations applicable in Germany
Permitted copper pipes	DIN EN 1057
Approval of press connectors for use with copper pipes	DVGW-Arbeitsblatt GW 392

Regulations from section: Sealing elements

Scope / Notice	Regulations applicable in Germany
Area of use of the EPDM sealing element ■ Heating	DIN EN 12828

Regulations from section: Corrosion

Scope / Notice	Regulations applicable in Germany
Regulations for external corrosion protection	DIN EN 806-2
Regulations for external corrosion protection	DIN 1988-200
Regulations for external corrosion protection	DKI-Informationsdruck i. 160

Regulations from section: Storage

Scope / Notice	Regulations applicable in Germany
Requirements for material storage	DIN EN 806-4, Chapter 4.2

Regulations from section: Leakage test

Scope / Notice	Regulations applicable in Germany
Test on a system that is finished but not yet covered	DIN EN 806-4
Leakage test for water installations	ZVSHK-Merkblatt: "Dichtheitsprüfungen von Trinkwasserinstallationen mit Druckluft, Inertgas oder Wasser"

Regulations from section: Maintenance

Scope / Notice	Regulations applicable in Germany
Operation and maintenance of potable water installations	DIN EN 806-5

2.2 Intended use



Coordinate the use of the system for areas of use and media other than those described with the Viega Service Center.

2.2.1 Areas of use

Use is possible in the following areas among others:

- Drinking water installations
- Industrial and heating systems
- Wet sprinkler systems with dimensions d 22–54 with copper pipe, only R290 hard, see ↗ „Regulations from section: Fields of application“ on page 7
- Fire extinguishing systems, see ↗ „Regulations from section: Fields of application“ on page 7
 - wet
- Solar installations with flat collectors
- Solar installations with vacuum collectors (only with FKM sealing element)
- Compressed air systems
- District heat supply systems (only with FKM sealing element)
- Low-pressure steam systems (only with FKM sealing element)
- Cooling water pipelines (closed circuit)

Drinking water installation

For planning, execution, operation and maintenance of potable water installations, observe the applicable regulations, see ↗ „Regulations from section: Fields of application“ on page 7.

Maintenance

Inform your customer or the operator of the potable water installation that the system has to be maintained on a regular basis, see ↗ Chapter 3.5 „Maintenance“ on page 27.

Sealing element

Only EPDM sealing elements are approved in potable water installations. Do not use any other sealing elements.

2.2.2 Media

The system is suitable for the following media, amongst others:

For the applicable directives, see  „Regulations from section: Media“ on page 7.

- Drinking water in respect of the pipe material, except the components (press connectors, fittings, devices, etc.):
 - at pH-values ≥ 7.4
 - at pH values between 7.0 and 7.4 and a TOC value ≤ 1.5 mg/l
- Heating water for pump hot water heating systems
- Compressed air in compliance with the specification of the sealing elements being used
 - EPDM at oil concentration < 25 mg/m³
 - FKM at oil concentration ≥ 25 mg/m³
- Anti-freeze, cooling brines up to a concentration of 50 %
- Steam in low-pressure steam systems (only with FKM sealing element)

2.3 Product description

2.3.1 Overview

The piping system consists of press connectors for copper pipes and the corresponding press tools.



Fig. 1: Profipress range selection

The system components are available in the following dimensions:
d 12 / 14 / 15 / 16/ 18 / 22 / 28 / 35 / 42 / 54.

2.3.2 Pipes

Only copper pipes that comply with the pertinent regulations may be used, see [Chapter 2.1 „Standards and regulations“](#) on page 7:

Various wall thicknesses are permitted depending on the area of use (potable water and heating installations).

Certified copper pipes in potable water installations

d x s [mm]	Volume per metre of pipe [l/m]	Pipe weight [kg/m]
12 x 0.8	0.09	0.25
12 x 1.0	0.08	0.31
14 x 0.8	0.12	0.29
14 x 1.0	0.11	0.36
15 x 1.0	0.13	0.39
16 x 1.0	0.15	0.42
18 x 1.0	0.20	0.48
22 x 1.0	0.31	0.59
28 x 1.0	0.53	0.76
28 x 1.5	0.49	1.11
35 x 1.2	0.84	1.13
35 x 1.5	0.80	1.41
42 x 1.2	1.23	1.37
42 x 1.5	1.20	1.70
54 x 1.5	2.04	2.20
54 x 2.0	1.96	2.91

Certified copper pipes in heating installations

d x s [mm]	Volume per metre of pipe [l/m]	Pipe weight [kg/m]
12 x 0.7	0.09	0.22
12 x 1.0	0.08	0.31
14 x 0.8	0.12	0.29
14 x 1.0	0.11	0.36
15 x 0.8	0.14	0.32
15 x 1.0	0.13	0.39

d x s [mm]	Volume per metre of pipe [l/m]	Pipe weight [kg/m]
16 x 1.0	0.15	0.42
18 x 0.8	0.13	0.39
18 x 1.0	0.20	0.48
22 x 1.0	0.31	0.59
28 x 1.0	0.53	0.76
35 x 1.2	0.84	1.13
42 x 1.2	1.23	1.37
54 x 1.5	2.04	2.20

Laying and fixing pipes

Only pipe clamps with noise insulation inlays should be used.

Observe the general rules of fixing technology:

- Fixed pipelines should not be used as support for other pipelines and components.
- Do not use pipe hooks.
- Observe distance to connectors.
- Observe the expansion direction – plan fixed and gliding points.

Affix the pipelines in such a way as to de-couple them from the installation body, so that they cannot transfer any structure-borne sound, resulting from thermal expansion or possible pressure surges, onto the installation body or other components.

Observe the following fixing intervals:

Interval between the pipe clamps

d [mm]	Fixing interval between the pipe clamps [m]
12.0	1.25
14.0	1.25
15.0	1.25
16.0	1.25
18.0	1.50
22.0	2.00
28.0	2.25
35.0	2.75
42.0	3.00
54.0	3.50

Length expansion

Pipelines expand with heat. Heat expansion is dependent on the material. Changes in length lead to tension within the installation. These tensions must be equalised with suitable measures.

The following are effective:

- Fixed and gliding points
- Expansion equalisation joints (expansion bends)
- Compensators

Heat expansion co-efficient of copper

Material	Heat expansion co-efficient α [mm/mK]	Example: Length expansion with pipe lengths = 20 m and $\Delta T = 50$ K [mm]
Copper	0.0166	16.6

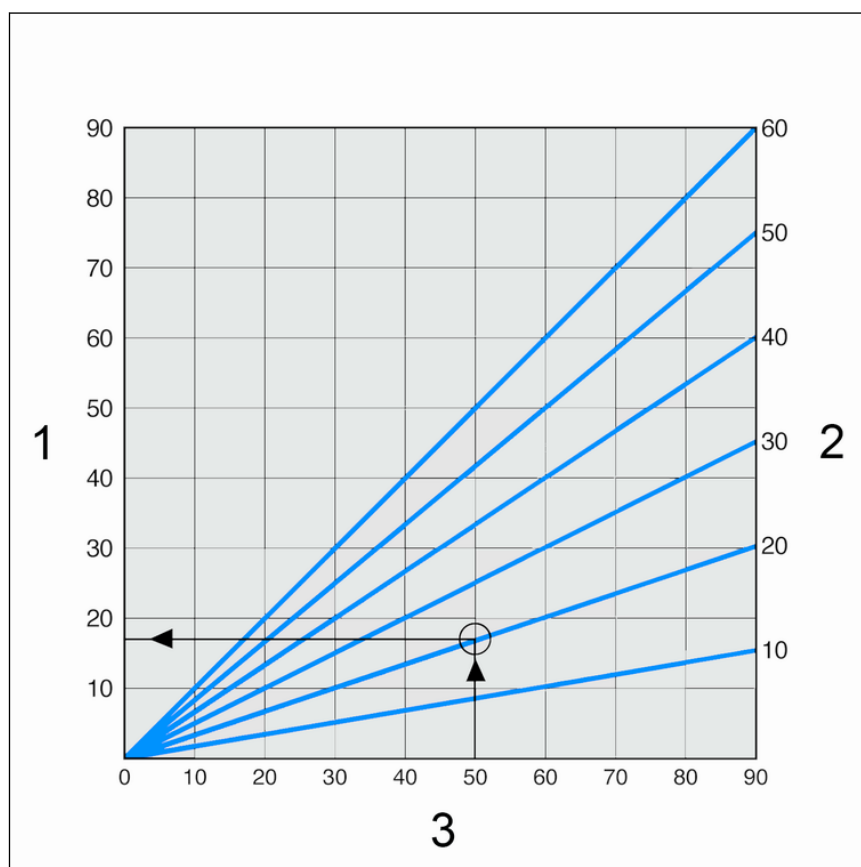

Fig. 2: Length expansion of copper pipes

- 1 - Length expansion $\vec{\Delta l}$ [mm]
- 2 - Pipe length \vec{l}_0 [m]
- 3 - Temperature difference $\vec{\Delta \vartheta}$ [K]

The length expansion Δl can be taken from the diagram or can be calculated using the following formula:

$$\Delta l = \alpha \text{ [mm/mK]} \times L \text{ [m]} \times \Delta\vartheta \text{ [K]}$$

2.3.3 Press connectors

Press connectors are available in a number of shapes. An overview of the press connectors suitable for the system can be found in the catalogue.

The press connectors in the Profipress system consist of the following materials:

- Copper
- Gunmetal/silicon bronze (Sanpress)

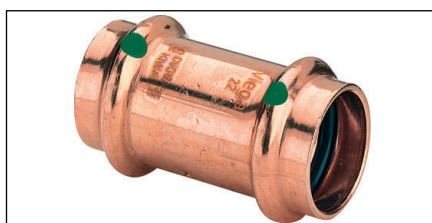

Fig. 3: Press connectors

The press connectors have a circumferential bead in which the sealing element lies. The connector is deformed upstream and downstream of the bead and permanently connected to the pipe during pressing. The sealing element is not deformed during pressing.

SC-Contur

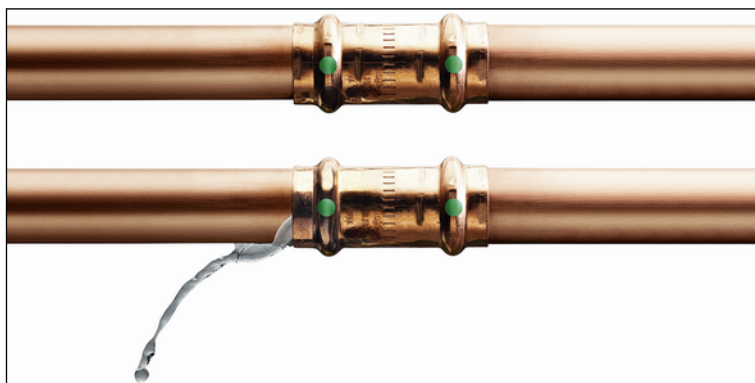

Fig. 4: SC-Contur

Viega press connectors are equipped with the SC-Contur. The SC-Contur is a safety technology that is certified by the DVGW and ensures that the connector is guaranteed to be leaky in an unpressed state. In this way, inadvertently unpressed connections are noticed immediately when filling the system.

Viega ensures that inadvertently unpressed connections during installation become visible when the system is filled.

- with wet leakage test in the pressure range from 0.1–0.65 MPa (1.0–6.5 bar)
- with dry leakage test in the pressure range from 22 hPa–0.3 MPa (22 mbar–3.0 bar)

The special components (model 2215.1NC, 2215.2NC, 9777.9, 9778.0, 9778.1 and 2252) in the dimensions d 10 and d 14 have no SC-Contur.

2.3.4 Sealing elements

The press connectors are factory-fitted with EPDM sealing elements. For areas of use with higher thermal resistance, such as e.g. in the case of district heat supply or low-pressure steam systems, the press connectors must be equipped with FKM sealing elements.

The sealing elements can be distinguished as follows:

- EPDM sealing elements are polished black.
- FKM sealing elements are matt black.

Area of use of the EPDM sealing element

Area of use	Potable water	Heating	Solar installations	Compressed air	Technical gases
Area of use	all pipeline sections	Pump hot water heating system	Solar circuit	all pipeline sections	all pipeline sections
Operating temperature [$T_{max.}$]	110 °C	110 °C	¹⁾	60 °C	—
Operating pressure [P_{max}]	1.6 MPa (16 bar)	1.6 MPa (16 bar)	0.6 MPa (6 bar)	1.6 MPa (16 bar)	—
Comments	see notes ☞ Chapter 2.2.2 „Media“ on page 10	T_{max} 105 °C ²⁾ 95 °C with radiator connection	for flat collectors	dry, oil content < 25 mg / m ³	¹⁾

¹⁾ Consultation with the Viega Service Center required.

²⁾ see ☞ „Regulations from section: Sealing elements“ on page 8

Area of use of the FKM sealing element

Area of use	District heat supply	Solar installations	Compressed air
Use	District heat supply systems behind the external wall lead-in	Solar circuit	all pipeline sections
Operating temperature [$T_{max.}$]	140 °C	¹⁾	60 °C

¹⁾ Consultation with the Viega Service Center required.

Area of use	District heat supply	Solar installations	Compressed air
Operating pressure [P_{max}]	1.6 MPa (16 bar)	0.6 MPa (6 bar)	1.6 MPa (16 bar)
Comments	—	—	dry, oil content $\geq 25 \text{ mg / m}^3$

¹⁾ Consultation with the Viega Service Center required.

2.3.5 Markings on components

Markings on press connectors

The press connectors are marked with a coloured dot. This identifies the SC-Contur, where the test medium would escape in the case of an inadvertently unpressed connection.

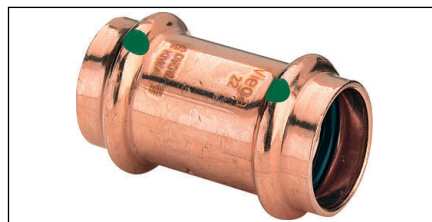

Fig. 5: Marking on the press connector

The green dot indicates that the system is suitable for potable water and is equipped with the SC-Contur.

2.3.6 Mixed installations

In potable water installations, piping components from different metals can have a detrimental effect on each other and e.g. cause corrosion. For instance, no copper pipe may be installed directly upstream from a galvanised steel pipe.



The flow rule must be observed in all mixed installations with pipes made of copper and galvanised steel.

Please contact the Viega Service Center for questions on this subject.

2.4 Information for use

2.4.1 Corrosion

Overground pipelines and fittings in rooms do not normally require external corrosion protection.

There are exceptions in the following cases:

- Contact with aggressive building materials such as nitrite or materials containing ammonium
- in aggressive surroundings

If external corrosion protection is required, observe the pertinent guidelines, see ↗ „Regulations from section: Corrosion“ on page 8.

3 Handling

3.1 Transport

Observe the following when transporting pipes:

- Do not pull the pipes over the sill. The surface could be damaged.
- Secure pipes during transportation. Pipes may become bent due to shifting.
- Do not damage the protective caps on the pipe ends and do not remove them until immediately before mounting. Damaged pipe ends may not be pressed.



In addition, observe the instructions provided by the pipe manufacturer.

3.2 Storage

For storage, comply with the requirements specified in the applicable regulations, see [☞ „Regulations from section: Storage“ on page 8:](#)

- Store components in a clean and dry place.
- Do not store the components directly on the floor.
- Provide at least three points of support for the storage of pipes.
- Where possible, store different sizes separately.
Store small sizes on top of larger sizes if separate storage is not possible.



In addition, observe the instructions provided by the pipe manufacturer.

3.3 Assembly information

3.3.1 Mounting instructions

Checking system components

System components may, in some cases, become damaged through transportation and storage.

- Check all parts.
- Replace damaged components.
- Do not repair damaged components.
- Contaminated components may not be installed.

3.3.2 Potential equalisation



DANGER! Danger due to electrical current

An electric shock can lead to burns and serious injury and even death.

Because all metallic piping systems conduct electricity, unintentional contact with a live part can lead to the whole piping system and components connected to it (e. g. radiators) becoming energised.

- Only allow electrical work to be carried out by qualified electricians.
- Always integrate the metallic piping system into the potential equalisation.



It is the fitter of the electrical system who is responsible for ensuring that the potential equalisation is tested and secured.

3.3.3 Permitted exchange of sealing elements



Important instruction

With their material-specific qualities, sealing elements in press connectors are adapted for use with the corresponding media and/or the areas of use of the piping systems and are generally only certified for them.

The exchange of a sealing element is generally permitted. The sealing element must be exchanged for a designated spare part for the intended application ↪ Chapter 2.3.4 „Sealing elements“ on page 15. The use of other sealing elements is not permitted.

Exchanging a sealing element is permitted in the following situations:

- if the sealing element in the press connector is obviously damaged and should be exchanged for a Viega replacement sealing element made of the same material
- if an EPDM sealing element should be exchanged for an FKM sealing element (higher thermal resistance, e.g. for industrial use)

3.3.4 Space requirements and intervals

Pressing between pipelines

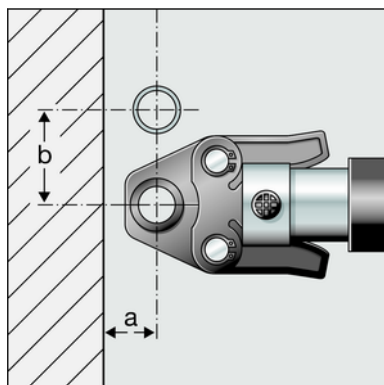

Space requirement PT1, type 2 (PT2), PT3-EH, PT3-AH, Pressgun 4B, 4E, 5

d	12	14	15	16	18	22	28	35	42	54
a [mm]	20	20	20	20	20	25	25	30	45	50
b [mm]	50	50	50	55	55	60	70	85	100	115

Space requirement Picco, Pressgun Picco

d	12	14	15	16	18	22	28	35
a [mm]	25	25	25	25	25	25	25	25
b [mm]	55	60	60	60	60	65	65	65

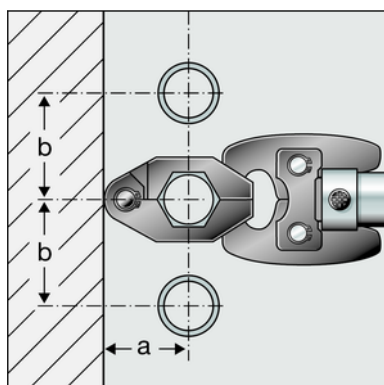

Space requirement press ring

d	12	14	15	16	18	22	28	35	42	54
a [mm]	40	40	40	45	45	45	50	55	60	65
b [mm]	45	60	50	60	55	60	70	75	85	90

Pressing between pipe and wall

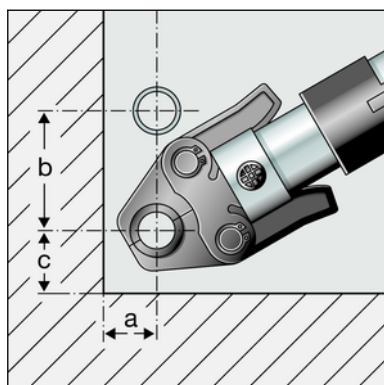

Space requirement PT1, type 2 (PT2), PT3-EH, PT3-AH, Pressgun 4B, 4E, 5

d	12	14	15	16	18	22	28	35	42	54
a [mm]	25	25	25	25	25	30	30	50	50	55
b [mm]	65	65	65	75	75	80	85	95	115	140
c [mm]	40	40	40	40	40	40	50	50	70	80

Space requirement Picco, Pressgun Picco

d	12	14	15	16	18	22	28	35
a [mm]	30	30	30	30	30	30	30	30
b [mm]	70	70	70	70	70	75	80	80
c [mm]	40	40	40	40	40	40	40	40

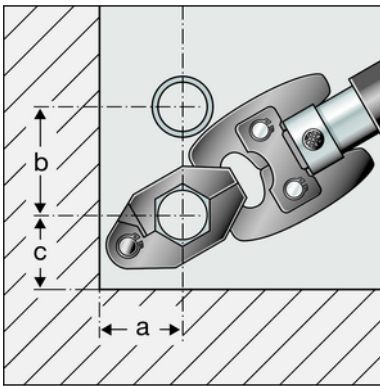
Space requirement press ring

d	12	14	15	16	18	22	28	35	42	54
a [mm]	40	40	40	45	45	45	50	55	60	65
b [mm]	45	50	50	55	55	60	70	75	85	90
c [mm]	35	35	35	40	40	40	45	50	55	65

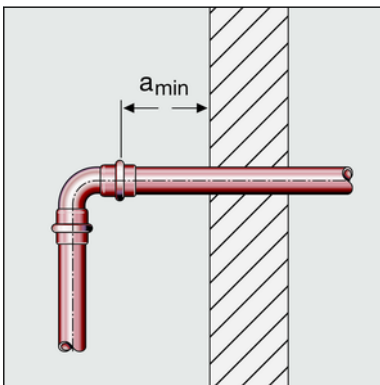
Distance to walls

Minimum interval with d 12–54

Press machine	a_{min} [mm]
PT1	45
Type 2 (PT2)	50
Type PT3-EH	
Type PT3-AH	
Pressgun 4E / 4B	
Pressgun 5	35
Picco / Pressgun Picco	

Interval between the pressings



NOTICE!

Leaky press connections due to pipes being too short

If two press connectors are to be mounted next to one another onto a pipe without an interval, the pipe must not be too short. If the pipe is not inserted up to the prescribed insertion depth in the press connector during pressing, the connection may become leaky.

With pipes with a diameter of d 12–28, the length of the pipe must be at least as long as the total insertion depth of both press connectors.

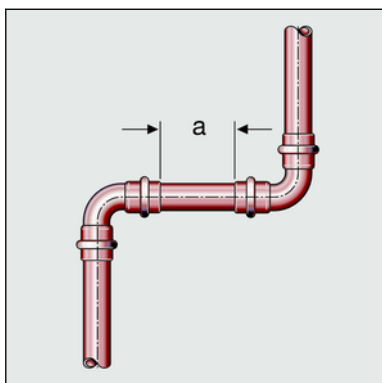

Minimum interval with press jaws d 12–54

d	a_{\min} [mm]
12	0
14	0
15	0
16	0
18	0
22	0
28	0
35	10
42	15
54	25

Z dimensions

For the Z dimensions, refer to the respective product page in the online catalogue.

3.3.5 Required tools

The following tools are required for production of a press connection:

- pipe cutter or a fine-toothed hacksaw
- deburrer and coloured pen for marking
- press machine with constant pressing force
- Press jaw or press ring with corresponding hinged adapter jaw, suitable for the pipe diameter and suitable profile



Fig. 6: Press jaws

Recommended Viega press machines:

- Pressgun 5
- Pressgun Picco
- Pressgun 4E / 4B
- Picco
- Type PT3-AH
- Type PT3-H / EH
- Type 2 (PT2)

3.4 Assembly

3.4.1 Replacing the sealing element

Removing the sealing element



Do not use pointed or sharp-edged objects to remove the sealing element. These could damage the sealing element or bead.

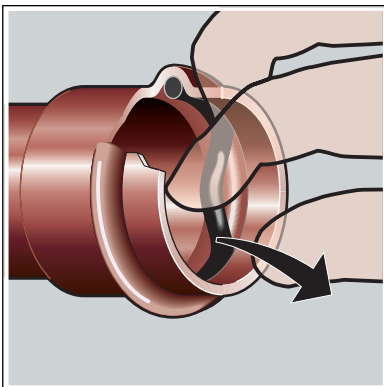

- Remove the sealing element from the bead.

Inserting the sealing element

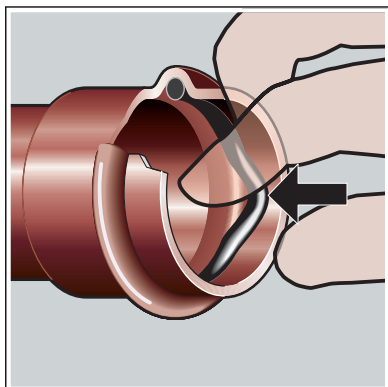

- Insert a new, undamaged sealing element into the bead.
- Ensure that the complete sealing element is in the bead.

3.4.2 Bending pipes

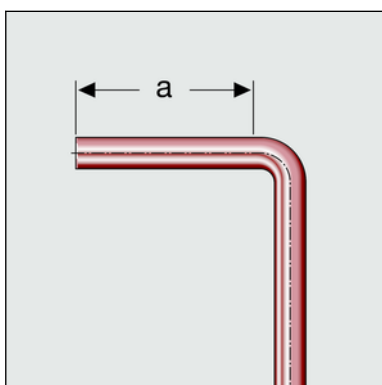

Copper pipes in the sizes d 12, 14, 15, 16, 18, 22 and 28 can be bent cold with commercially available bending equipment (radius at least $3.5 \times d$).

The pipe ends (a) must be at least 50 mm long so that the press connectors can be mounted properly.

3.4.3 Shortening the pipes



NOTICE!

Leaky press connections due to damaged material!

Press connections can become leaky due to damaged pipes or sealing elements.

Observe the following instructions to avoid damage to pipes and sealing elements:

- Do not use cutting discs (angle grinders) or flame cutters when cutting to length.
- Do not use grease or oils (e. g. cutting oil).

For information about tools, also see [Chapter 3.3.5 „Required tools“](#) on page 22.

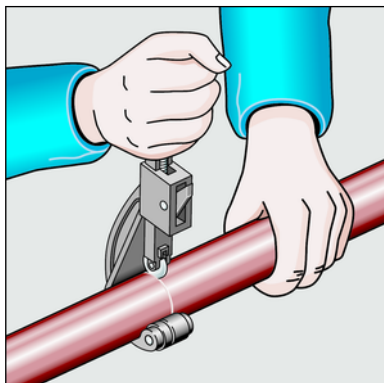

- Cut the pipe properly using a pipe cutter or fine-toothed hacksaw. Avoid grooves on the pipe surface.

3.4.4 Deburring the pipes

The pipe ends must be thoroughly deburred internally and externally after shortening.

Deburring prevents the sealing element being damaged or the that the press connector cants when mounted. Use of a deburrer (model 2292.2) is recommended.



NOTICE!
Damage due to the wrong tool!

Do not use sanding disks or similar tools when deburring. The pipes could be damaged by these.

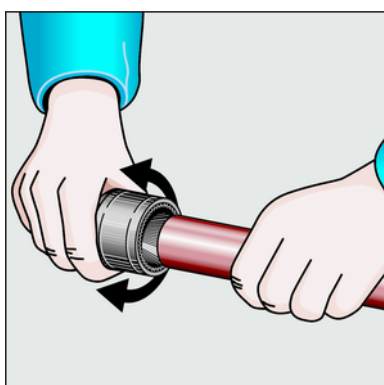

- Deburr the inside and outside of the pipe.

3.4.5 Pressing the connection

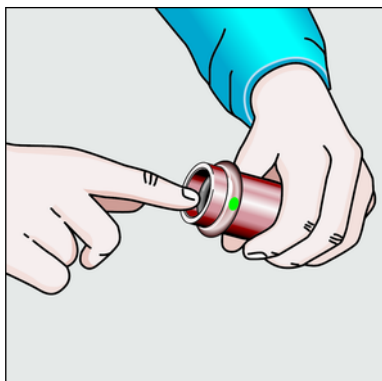

Requirements:

- The pipe end is not bent or damaged.
- The pipe is deburred.
- The correct sealing element is in the press connector.
EPDM = polished black
FKM = matt black
- The sealing element is undamaged.
- The complete sealing element is in the bead.

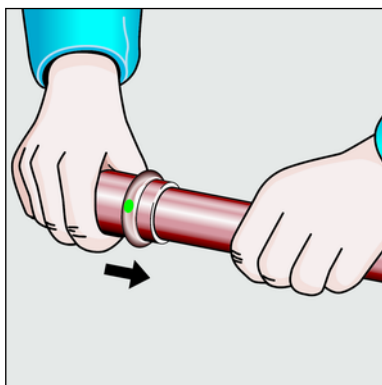

- Push the press connector onto the pipe as far as it will go.

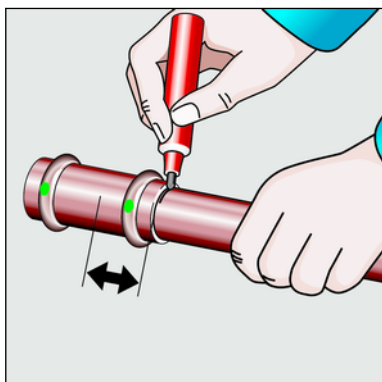

- Mark the insertion depth.

- Place the press jaw onto the press machine and push the retaining bolt in until it clicks into place.

INFO! Observe the press tool instruction manual.

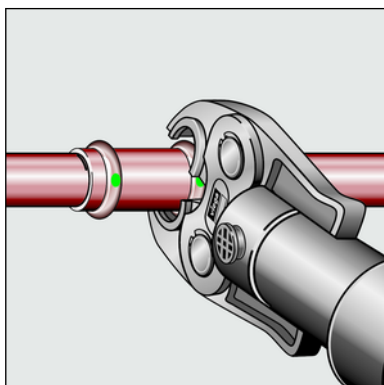

- Open the press jaw and place at a right-angle onto the connector.
- Check the insertion depth using the marking.
- Ensure that the press jaw is placed centrally on the bead of the press connector.

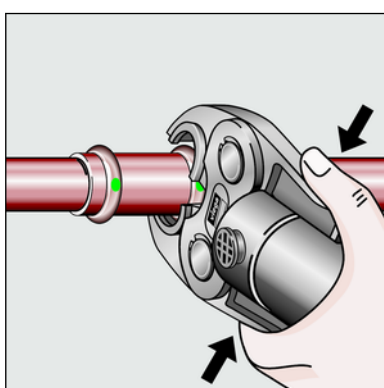

- Carry out the pressing process.

- Open and remove the press jaw.
 - ⇒ Connection is pressed.

3.4.6 Leakage test

The installer must perform a leakage test before commissioning.

Carry out this test on a system that is finished but not yet covered.

Observe the applicable regulations, see ↗ „Regulations from section: Leakage test“ on page 8.

The leakage test pursuant to the applicable regulations must also be carried out for non-potable water installations, see ↗ „Regulations from section: Leakage test“ on page 8.

Document the result.

3.5 Maintenance

Observe the applicable regulations for the operation and maintenance of drinking water installations, see ↗ „Regulations from section: Maintenance“ on page 8.

3.6 Disposal

Separate the product and packaging materials (e. g. paper, metal, plastic or non-ferrous metals) and dispose of in accordance with valid national legal requirements.